

**12 EXB SCHEMATIC WITH DUAL BATTERY  
BANK SWITCH**

**DC DYNAMICS DIVISION  
SOUTHEAST MARINE SERVICES, LLC.  
800-487-0610  
[www.semarine.com](http://www.semarine.com)**

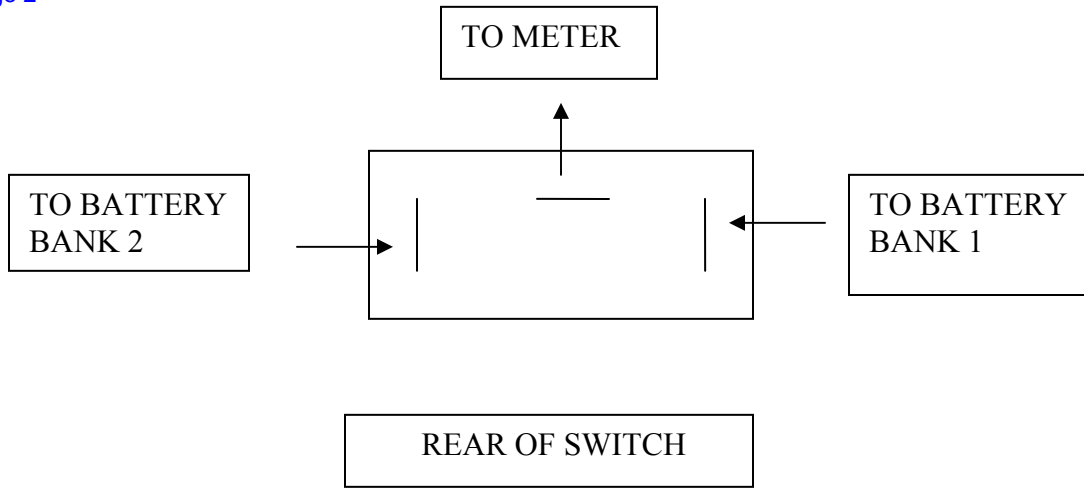

WIRING DIAGRAM FOR 2 BANK  
BATTERY SELECTOR SWITCH FOR  
SHORELINE METER



SOUTHEAST MARINE SERVICES, LLC  
34579 E. COLUMBIA AVE.  
SCAPPOOSE, OR 97056  
800-487-0610 503-543-7710 FAX 503-543-2845  
[www.semarine.com](http://www.semarine.com)  
email [larry@semarine.com](mailto:larry@semarine.com)

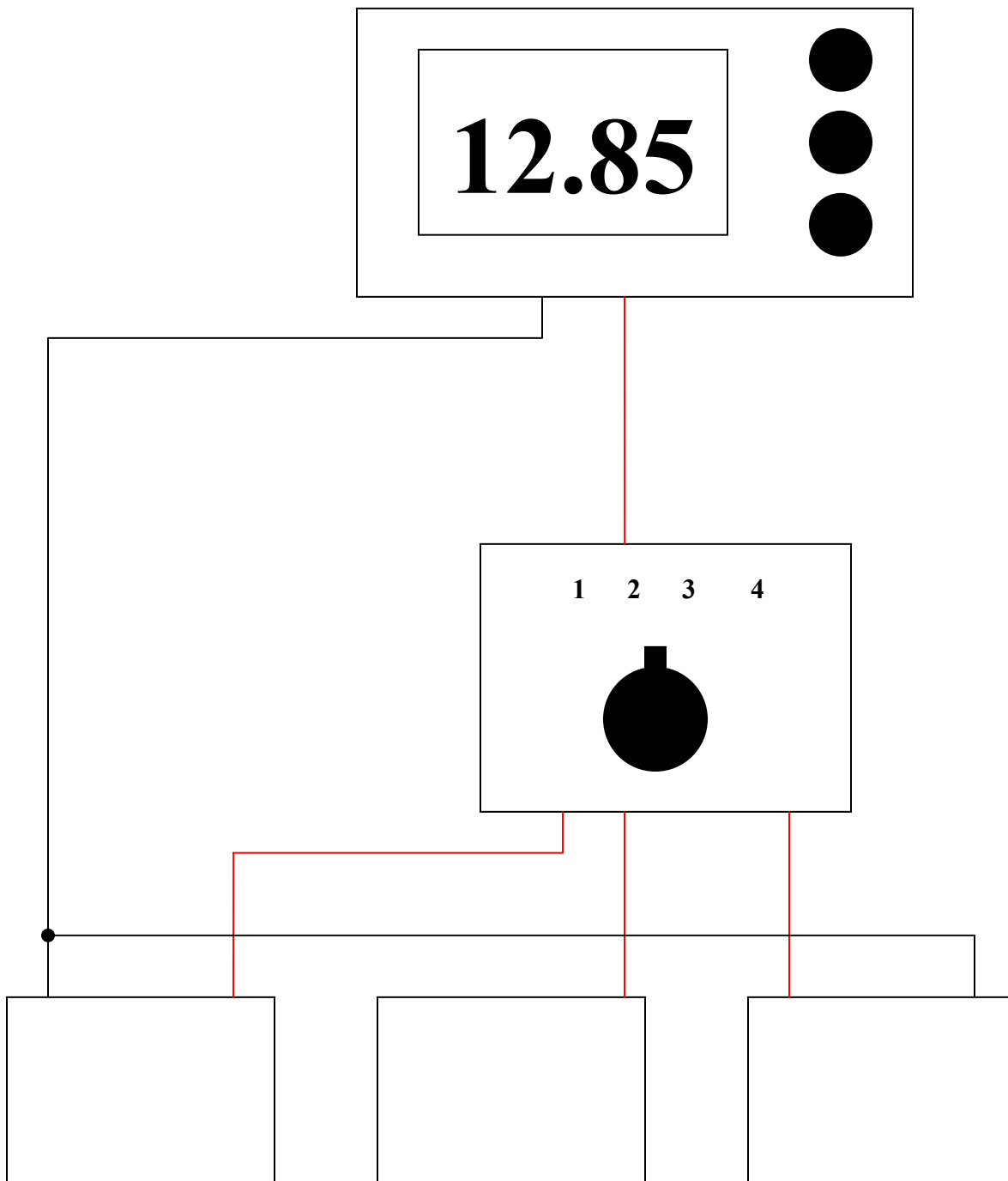

Battery 1

Battery 2

Battery 3

**12 EXB MONITOR WITH MULTIPLE BATTERY BANKS  
AND ROTARY SELECTOR SWITCH**

**DC DYNAMICS DIVISION**

**SOUTHEAST MARINE SERVICES, LLC.**

**800-487-0610 [www.semarine.com](http://www.semarine.com)**

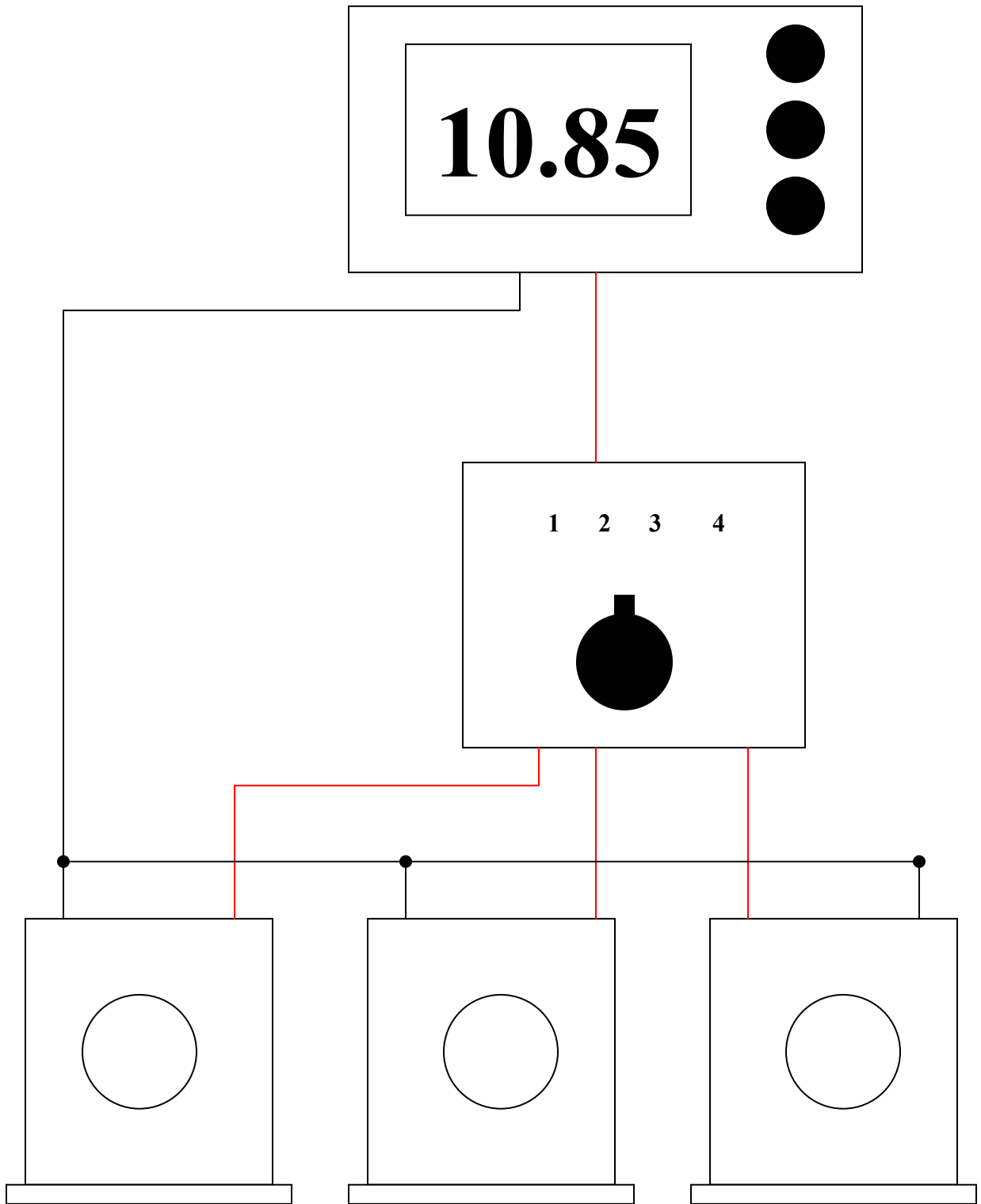

**200 AB CURRENT MONITOR WITH MULTIPLE 250 CT CURRENT SENSORS TO MEASURE AMPERE INPUT OR DRAW FROM MULTIPLE LOADS OR CHARGING SOURCES**  
**DC DYNAMICS DIVISION,**  
**SOUTHEAST MARINE SERVICES, LLC**  
**800-487-0610 [www.semarine.com](http://www.semarine.com)**

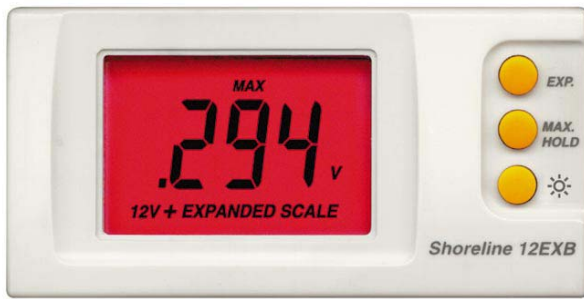

## 12EXB Battery Monitor

Thank you for purchasing the Shoreline 12EXB. The 12EXB was designed by boaters for boaters and should provide many years of service with little or no maintenance.

### Introduction

There are many methods of determining the remaining capacity of a 12V battery. The most complicated systems measure the current going in and out of the battery and calculate the remaining capacity. An accurate indication can be quite difficult due to the many variables like age of the battery, temperature, charge method and load conditions just to name a few. Most of these systems are costly and their accuracy will be determined by the data provided.

At Shoreline, we believe that an accurate expanded scale meter and a little experience will tell you what you need to know about your batteries.

### Expanded Scale Mode

The 12EXB is an expanded scale voltmeter designed to give you a detailed view of the voltage around 12V. As explained in many text books about battery systems, the difference between a fully charged battery and a dead battery can be as small as 0.500V. It would be very costly to design a meter that could display all of the digits in a 12.500V reading. In the expanded scale mode the 12EXB removes the 12V from the display and allows a reading of .001V. For example: 12.789V would display 0.789V in the expanded scale mode and the reading 11.500V would show -0.500V. After a short period of time you will begin to understand how your batteries behave under various conditions. If you have two batteries, you can compare the reading to determine which battery is stronger.

### Maximum Hold

When the 12EXB is in this mode, the meter will store the highest reading measured. This is useful when you want to find out how high the battery voltage rose during charging.

### Back Light

The back light will brightly light when the button with the "sun" symbol is pressed. To conserve energy, the backlight is only lit when the button is pressed.

### Using the 12EXB

The 12EXB can be used as a valuable tool to troubleshoot various problems in the electrical system.

**Charging** - When the motor or charger is on the voltage should slowly increase and should then stop when the battery is charged.

**Loads** - As various loads are turned on, a voltage drop will be seen. A water pump can draw 1V while a overhead light will draw only 0.020V. If there is a short or problem these systems will drain more voltage than normal. For Example: A higher than normal voltage drop could tell you that your water pump has a bad bearing.

**Voltage** - The best time to determine the full charge voltage is with no load or charge input on the battery for 10 or more minutes. This voltage can be used as a reference point. A good time to look at this voltage is when you first turn on power when your about to go boating for the weekend. If the battery voltage is lower than normal you should check the battery for problems.

### Warranty and Repair

The 12EXB is warranted to be free from defects for one year from the date of purchase. If the 12EXB needs repair send the 12EXB and a copy of the receipt to:

Service & Repair  
Shoreline Electronics, Inc.  
2102 Walsh Ave. Suite F  
Santa Clara, CA 95050

If you have trouble installing or have questions about the 12EXB please contact us at the numbers below.

Phone: 408-987-7733 Fax: 408-987-7735  
E-mail: Shoreline@sprynet.com

## Where to Install the 12EXB

The best place to install the 12EXB is near the power distribution panel. If you have more than one battery in your system, you will be able to monitor the battery you have selected with the A/B switch or battery selection switch. The 12EXB should not be installed where it will be exposed directly to the weather or water.

## Preparing for Installation

The 12EXB uses an isolated power supply. This means that the 12EXB can measure either the battery that powers the 12EXB or a separate battery in the system. For most applications, you will measure the same battery that supplies power to the 12EXB. **To make this measurement a jumper must be connected between V- and IN- and V+ and IN+.**

## Installation

After you have decided where to place the 12EXB you must cut a hole 3 1/2" W x 1 5/8" H. Use the paper template on the right to assist in the installation. Before you cut the hole make sure that you have at least 2 1/2" clearance for the rear of the meter. The 12EXB has a unique hidden clamp system that allows installation of the meter from the front with no exposed screws. Please see the pictorial following this page for a more detailed explanation.

## Warning

It is important to remember that you are connecting the input directly to the 12V system. If the input wires become shorted the battery will melt the input wires. If possible, the 12V system should be turned off prior to installing the 12EXB. To prevent shorting, the connection to the 12EXB should be made prior to connecting to the 12V system. It is also a good idea to connect a 1/2A fuse in series with the power.

## Paper Template

1. Cut out paper template and tape to panel using masking tape.
2. Drill 4 1/4" holes on the corner as shown.
3. If panel is made of veneer, it is a good idea to score the cut line with a sharp razor to prevent chipping of veneer.
4. Using a key hole saw or jig saw cut out the hole.
5. A file or rasp can be used to clean up the hole edges.
6. With the PCB removed trial fit the case of the meter.
7. Pull cables through the terminal block hole in the case.
8. Using pictorial install mounting hardware.
9. Connect cables to meter. Make sure to install jumpers if meter power supply and battery to be measured are the same. Cables should be installed so that they will slide easily through the terminal block hole.
10. Adjust warning level to the desired setting.
11. Carefully slide PCB assembly into the case. Make sure the PCB is resting on the rails.
12. Place cover over meter.

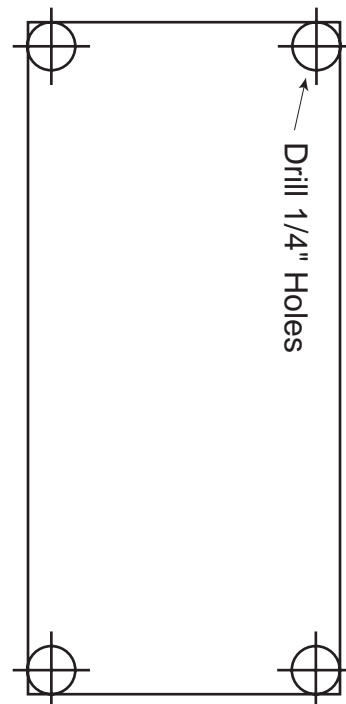

**Installing Mounting Hardware**

"L" Mounting Bracket

1 b) Turn 90°

1a) With the panel meter meter module removed install "L" mounting bracket. **Trimming the bracket may be necessary if the panel is thicker than 1/8".**

2 b) Slide "L" to rear

Mounting Block

2a) Install square mounting block as shown above. Slide toward the rear of the case to lock in place.

Mounting Screw

3) Insert screw in mounting block and through "L" bracket. Tighten screw until screw is snug. Do not over tighten.

Meter Module

4) Connect cables to the appropriate terminals. Make sure that power has been removed. If it is not possible to remove power make sure that wires are covered with black tape until they are ready to be connected. Carefully slide meter module in place. Make sure that PCB is sliding on guide rails.

5) Snap in the front panel in place. Make sure that the button can move freely

**Front Case Removal**

With the front case removal tool insert the two small tongues in the square holes on the top of the front case. Push the top of the tool towards the rear of the meter.

Use the tool to open the front case

**Typical Connection**

Jumpers Installed to Measure Input Power

To Battery or Power Distribution Panel

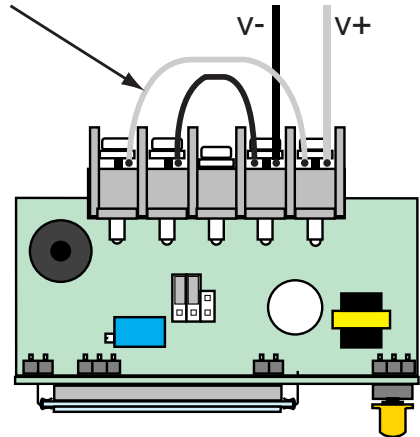

**Low Voltage Warning Adjustment**

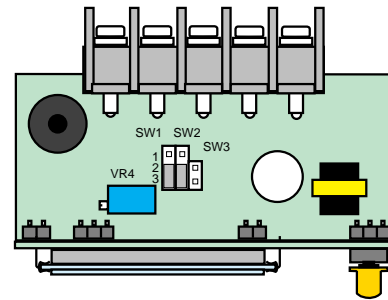

Place jumper on pins 2 & 3 of both SW1 and SW2. Using the display in the normal mode, adjust VR4 to the desired value. The factory has adjusted the warning to 11V.

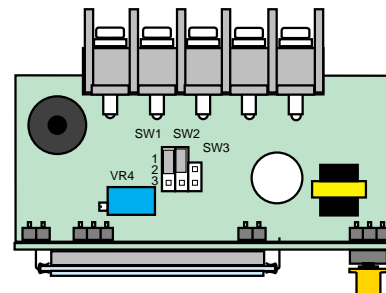

Reconnect the jumper on pins 1 & 2 for both SW1 and SW2. To disable the buzzer, move jumper of SW1 to pins 2 & 3.



## 200AB Current Monitor

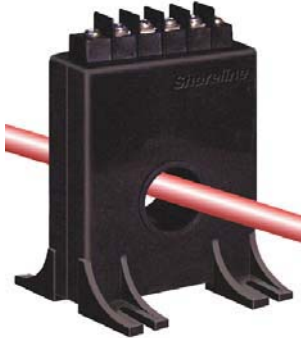

## 250CT Hall Effect Current Sensor

Thank you for purchasing the Shoreline 200AB and 250CT. The 200AB was designed to provide many years of service with little or no maintenance.

### Introduction

The 200AB was designed to accurately measure the current by using a hall effect current sensor 250CT. The hall effect sensor will measure the current of either the positive or negative cable by inserting one cable through the hole in the 250CT. The 250CT can be placed anywhere in the circuit. If you only have a single battery system, the sensor can be placed in the ground path of the battery. If you use two batteries and you want to monitor both of them, you can place the sensor after the power distribution panel. This will allow you to measure all of the current going into the power panel. This will not allow you to measure the current into the battery. If you want to measure all of the current in and out of both batteries, you will have to install the sensor in a ground path shared by both batteries.

### Dual Range Mode

The 200AB will display current in either the 200A range or a 20A range. The maximum value displayed in the 200A range will be 199.9A and 19.99A in the 20A range. Typically the system will use less than 20A

### Maximum Hold

When the 12EXB is in this mode, the meter will store the highest reading measured. This is useful when you want to find out how high the battery voltage rose during charging.

### Back Light

The back light will brightly light when the button with the "sun" symbol is pressed. To conserve energy, the backlight is only lit when the button is pressed.

### Using the 200AB

The 200AB and 250CT can be used as a valuable tools to troubleshoot various problems in the electrical system.

**Loads** - As various loads are turned on, a current value will be displayed. A water pump can draw 3 to 4A while a overhead light will draw only 500mA. If there is a short or problem these systems will drain more current than normal. For Example: A higher than normal current could tell you that your water pump has a bad bearing.

**Current** - If you know your current average current draw being used you can quickly estimate your battery life. For example: You are draining a constant 10A from your electrical system. If this 10A is drained for 1 hour, you are using 10A per hour or 10Ah. If your battery is rated for 100Ah it will take approximately 10 hours to drain your battery. Please note: It is not recommended to full drain your battery.

### Warranty and Repair

The 200AB is warranted to be free from defects for one year from the date of purchase. If the 200AB needs repair send the 200AB and a copy of the receipt to:

Service & Repair  
Shoreline Electronics, Inc.  
2102 Walsh Ave. Suite F  
Santa Clara, CA 95050

If you have trouble installing or have questions about the 200AB please contact us a the numbers below.

Phone: 408-987-7733 Fax: 408-987-7735  
E-mail: [info@shoreline-electronics.com](mailto:info@shoreline-electronics.com)  
Internet: [www.shoreline-electronics.com](http://www.shoreline-electronics.com)

## Where to Install the 200AB

The best place to install the 200AB is near the power distribution panel. If you have more than one battery in your system, you will be able to monitor the battery you have selected with the A/B switch or battery selection switch. The 200AB should not be installed where it will be exposed directly to the weather or water.

## Where to Install the 250CT

Before you install the 250CT you must determine which current path you want to measure. If you have one battery, the decision is quite simple. However most system have two batteries. The most convenient place to install the 250CT is in the ground or positive path leading to the power distribution panel.

## Preparing for Installation

The 200AB uses an isolated power supply. This means that the 200AB can measure either the battery that powers the 200AB or a separate battery in the system. For most applications, you will measure the same battery that supplies power to the 200AB.

## Installation

After you have decided where to place the 200AB you must cut a hole 3 1/2" W x 1 5/8" H. Use the paper template on the right to assist in the installation. Before you cut the hole make sure that you have at least 2 1/2" clearance for the rear of the meter. The 200AB has a unique hidden clamp system that allows installation of the meter from the front with no exposed screws. Please see the pictorial following this page for a more detailed explanation.

## Warning

It is important to remember that you are connecting the input directly to the 12V system. If the input wires become shorted the battery will melt the input wires. If possible, the 12V system should be turned off prior to installing the 200AB. To prevent shorting, the connection to the 200AB should be made prior to connecting to the 12V system. It is also a good idea to connect a 1/2A fuse in series with the power.

## Paper Template

1. Cut out paper template and tape to panel using masking tape.
2. Drill 4 1/4" holes on the corner as shown.
3. If panel is made of veneer, it is a good idea to score the cut line with a sharp razor to prevent chipping of veneer.
4. Using a key hole saw or jig saw cut out the hole.
5. A file or rasp can be used to clean up the hole edges.
6. With the PCB removed trial fit the case of the meter.
7. Pull cables through the terminal block hole in the case.
8. Using pictorial install mounting hardware.
9. Connect cables to meter. Make sure to install jumpers if meter power supply and battery to be measured are the same. Cables should be installed so that they will slide easily through the terminal block hole.
10. Adjust warning level to the desired setting.
11. Carefully slide PCB assembly into the case. Make sure the PCB is resting on the rails.
12. Place cover over meter.

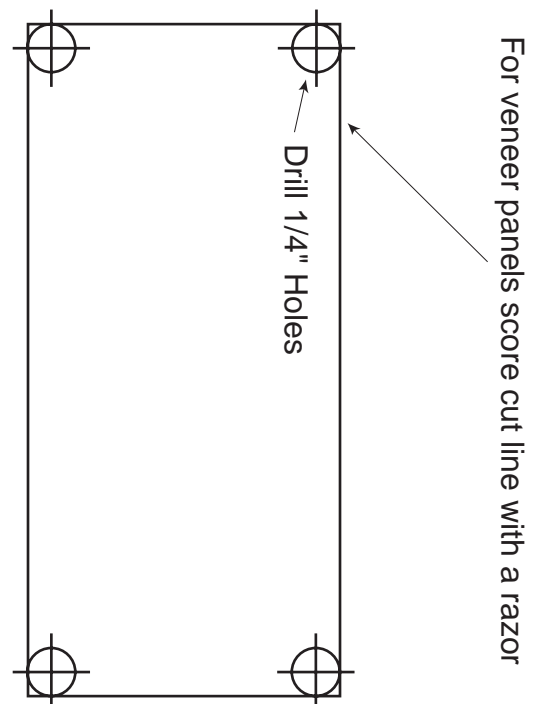

**Installing Mounting Hardware**

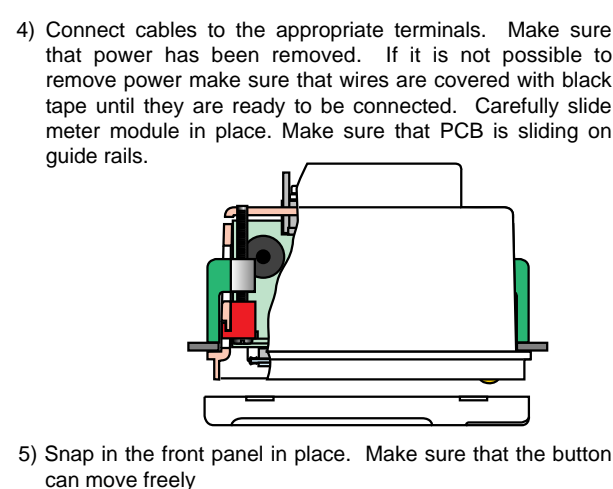
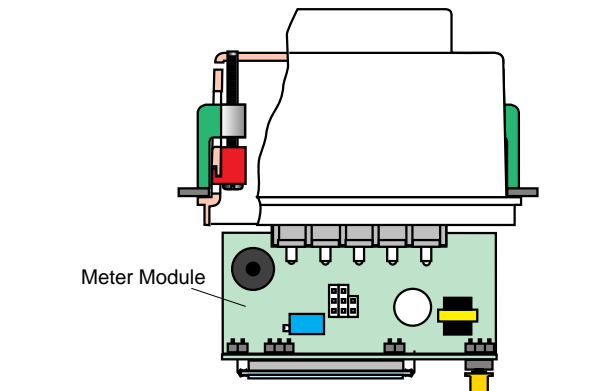
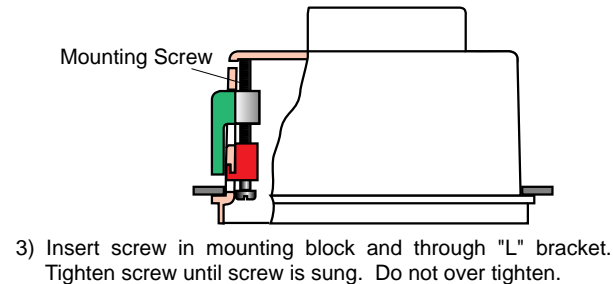
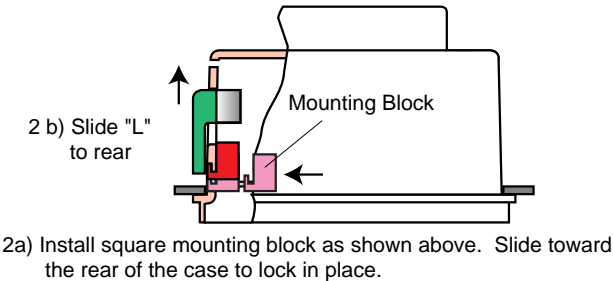
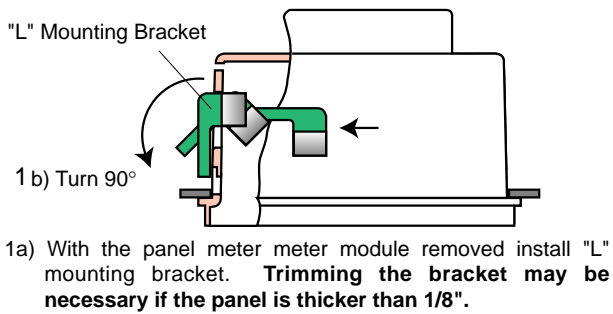

**Front Case Removal**

With the front case removal tool insert the two small tongues in the square holes on the top of the front case. Push the top of the tool towards the rear of the meter.

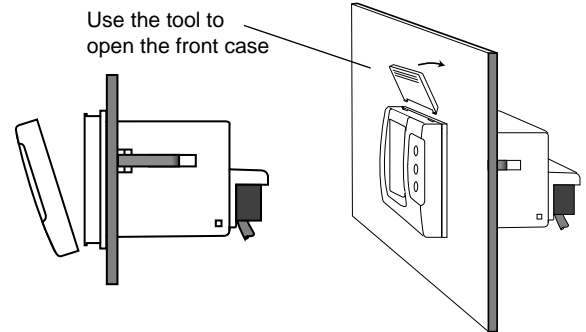

**Installing The 250CT**

Simply insert the wire to be measured through the hole in the 250CT. Please note, that an arrow on the side of the case shows the current direction. If the meter reads negative the current is flowing against the arrow. Using the below diagram as an example, connect the 250CT to the 200AB using a quality 4 wire transducer cable. (A 4 wire twisted pair phone cable can be used, but not recommended for boating applications. Use two screws to securely mount the 250CT.

**Typical Connection**

